

Bourns® ESD Protection & Power Impulse Protection

Short Form Catalog

Schottky Diodes

Transient Voltage Suppressor (TVS) Diodes

ChipGuard® ESD Suppressors

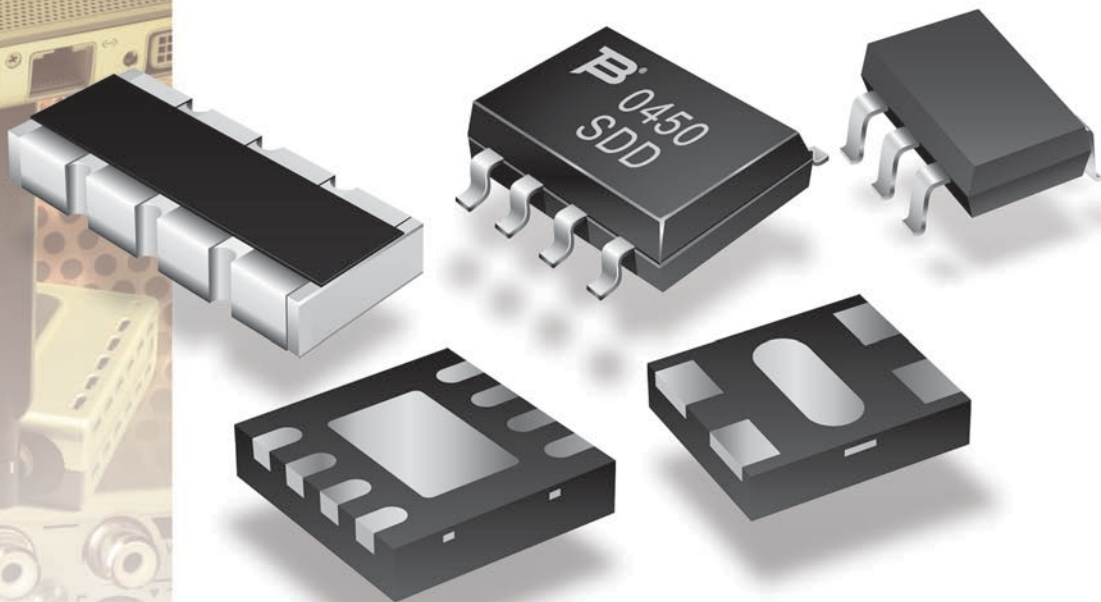

ESD Protection Product Applications

FEATURES

- RoHS compliant
- Discrete & array configurations
- Unidirectional & bidirectional configurations
- Standard, low and ultralow capacitance offering
- ESD protection per IEC 61000-4-2 standard
- EFT protection per IEC 61000-4-4 standard
- Surge protection per IEC 61000-4-5 standard
- SMT packages

APPLICATIONS

- General purpose ESD protection
- HDMI switch/splitter port protection
- Antenna protection
- High speed communication ports such as USB 2.0, IEEE1394, Gb Ethernet
- Fast communication ports such as USB1.1, 10/100b Ethernet ports
- RS232, RS422 & RS485 data port applications

USB 2.0 Single Port Protection

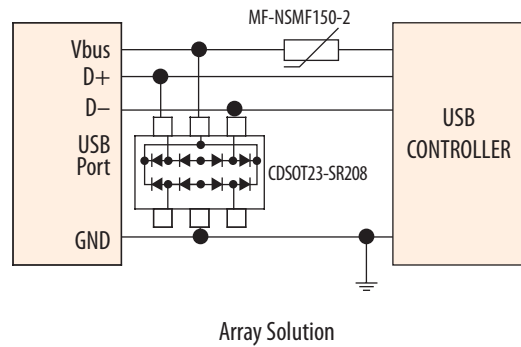
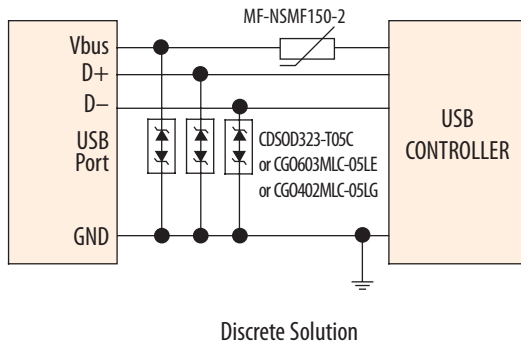

USB 1.1 Single Port Protection

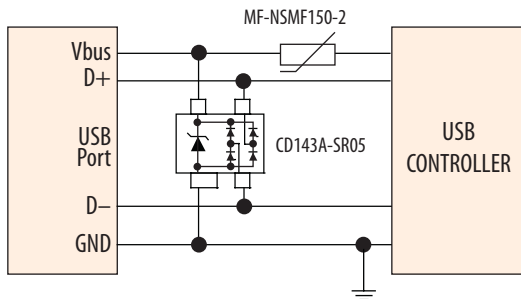

HDMI Port Protection

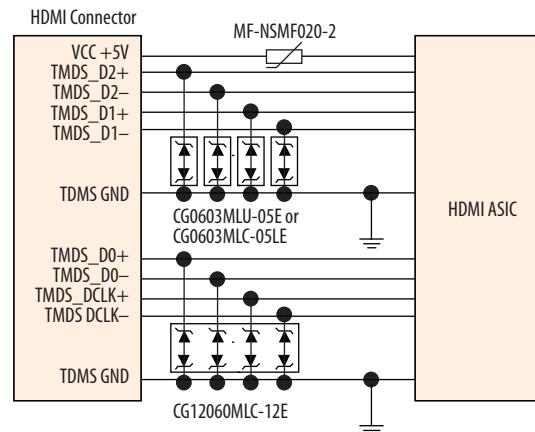

IEEE1394 (Firewire, i.Link) Protection

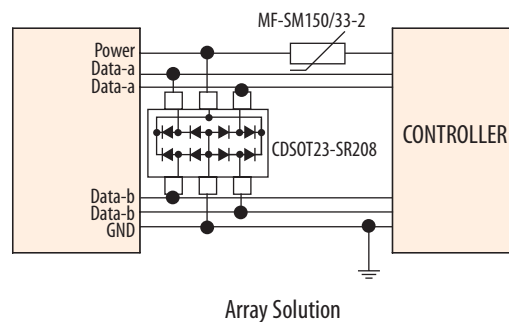
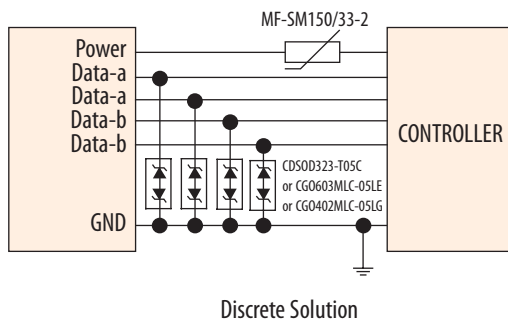

ESD Protection Product Applications

Ethernet 10/100 Protection

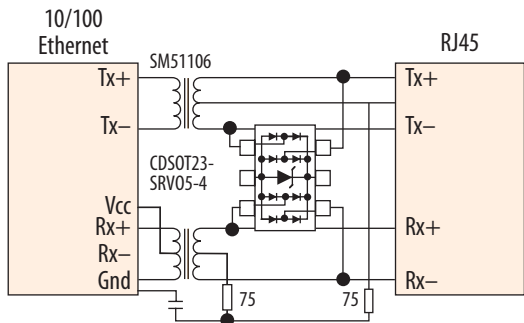

Ethernet 1000 Gigabit Protection

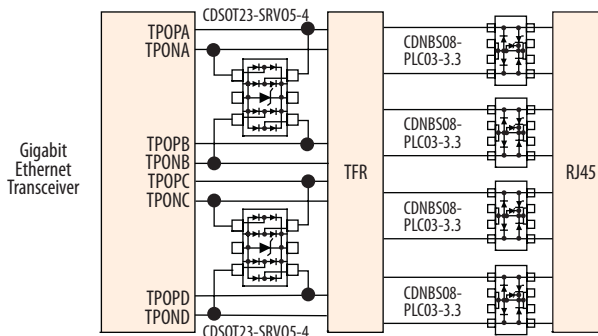

Gigabit Ethernet (GR 1089) Intra-Building Protection

T1/E1 Intra-Building Protection

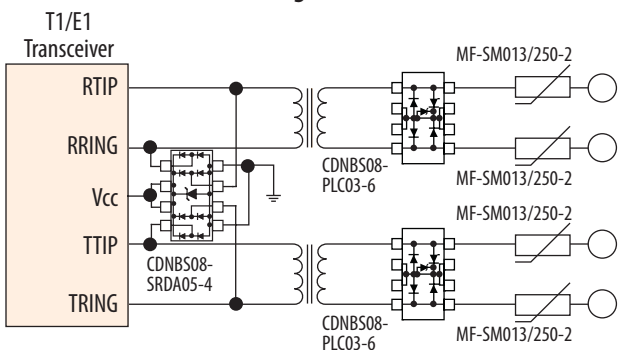

T1/E1 Outside Building Protection

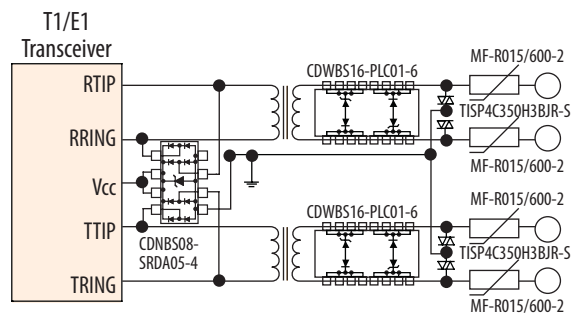

DVI Port Protection

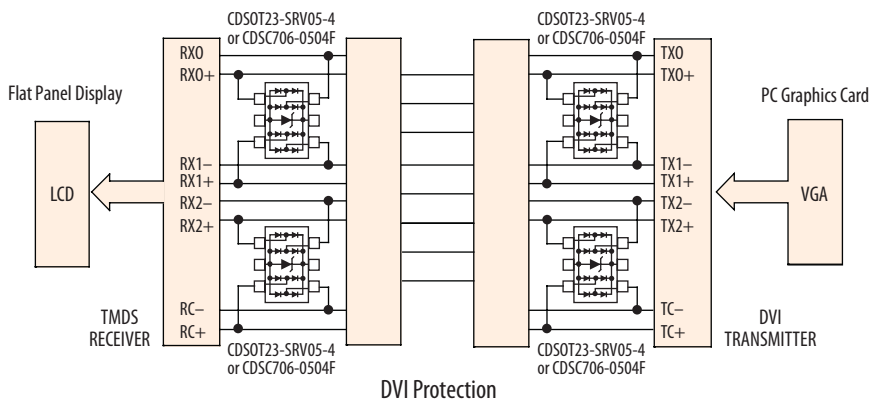

DVI Protection

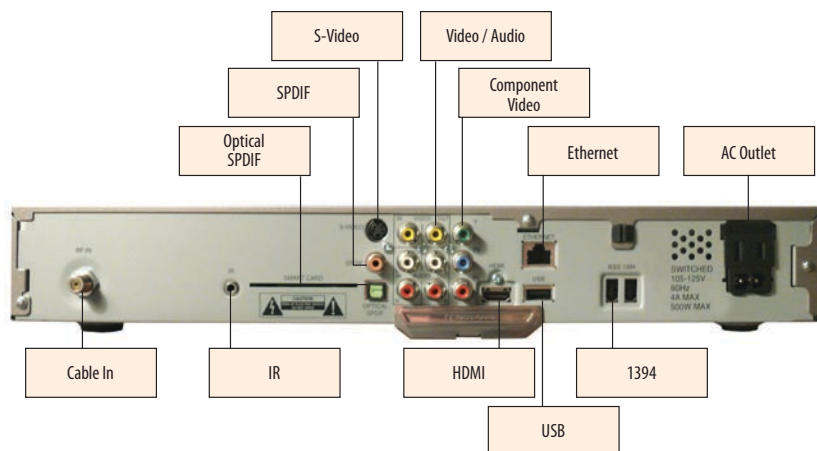

ESD Protection Requirements

Electrostatic discharge (ESD) occurs when a charge is exchanged between two objects of unequal charge potential. ESD, most often between people and metal objects, is a result of a build-up of electrons that behave as a capacitor when dielectric isolation is available. Manmade materials such as the sole of a shoe achieve dielectric isolation, while a person walking on carpet creates kinetic energy. The International Electro-technical Commission (IEC) developed a human model ESD event that allows designers to take adequate protection in their electrostatic applications. The IEC defined the ESD discharge impulse with a rise time of less than 1 ns and decay time of 60 ns as highlighted in the adjacent graph. The new standard, IEC61000-4-2 identifies four levels.

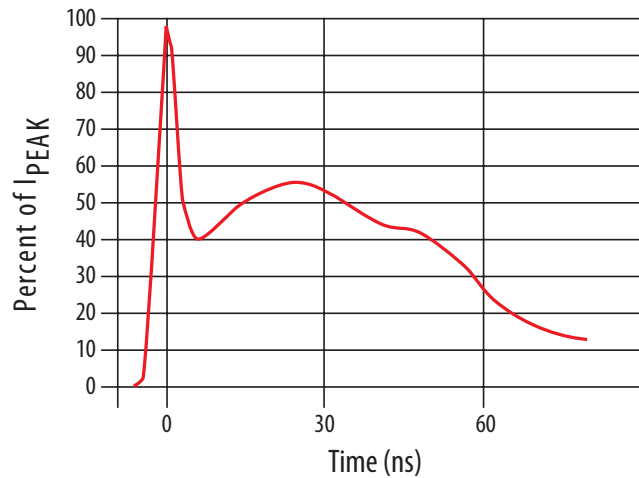

The different levels of the IEC61000-4-2 standard are outlined below:

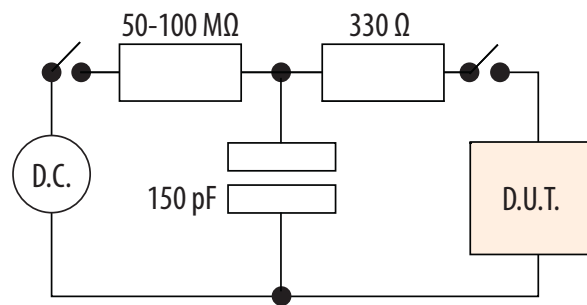

IEC61000-4-2 Level	Contact Voltage (kV)	Air Discharge Voltage (kV)	Peak Contact Current (A)	Contact Current @ 30 ns (A)	Contact Current @ 60 ns (A)
Level 1	2	2	7.5	4	2
Level 2	4	4	15	8	4
Level 3	6	8	22.5	12	6
Level 4	8	15	30	16	8

Integrated Circuit (IC) manufacturers of electrostatic sensitive devices design a level of protection into the IC to increase its robustness. However, protection circuits add cost to the device by consuming expensive silicon real estate. IC manufacturers design to standards to protect against board manufacturing processes such as IEC61000-4-2 Level 1, a 2 kV contact voltage. However, human body ESD voltages are nature-determined and can be 15 kV or more which will damage the IC.

IEC61000-4-2; Level 4 specifies an air discharge up to 15 kV to take this into consideration. It is common practice to protect all “people-interactive” data ports to Level 4, thereby limiting

product damage and increasing the robustness of the equipment. Therefore, the external ESD protector becomes the first level of protection with the IC providing residual second level protection in the design.

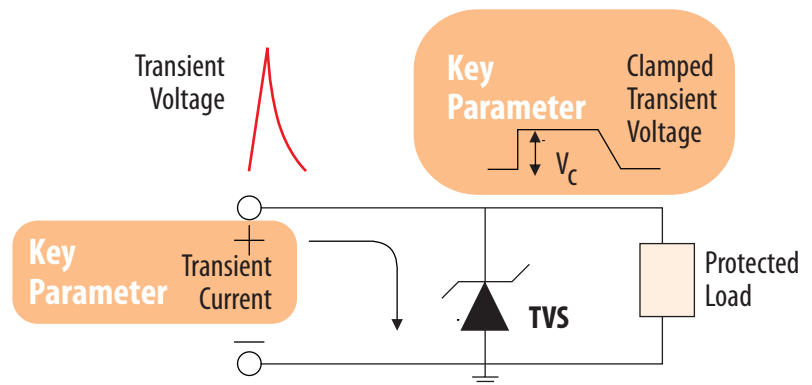

Discrete Small Signal Schottky Barrier Diodes



Part Number	Pkg. Size	Electrical Characterization (Ta = 25 °C)										
		V _{rrm} (V)	V _r (V)	I _o (mA)	I _{surge} (A)	V _f max. (V)	@ I _f (mA)	I _r max. (uA)	@ V _r (V)	C _t max. (pF)	@ V _r (V)	@ F (MHz)
CD0603-B00340	0603	45	40	30	0.5 (8.3ms)	0.37	1	1	40	1.5	1	1
CD1005-B00340	1005	45	40	30	0.5 (8.3ms)	0.37	1	1	40	1.5	1	1
CD0603-B0230	0603	35	30	200	2 (8.3ms)	0.50	200	30	30	12	10	1
CD1005-B0230	1005	35	30	200	3 (8.3ms)	0.50	200	30	30	12	10	1
CD0603-B0240	0603	45	40	200	2 (8.3ms)	0.55	200	10	30	12	10	1
CD1005-B0240	1005	45	40	200	3 (8.3ms)	0.55	200	10	30	12	10	1
CD1005-B0520	1005	30	20	500	2 (8.3ms)	0.47	500	100	20	12	10	1
CD0603-B0130L	0603	35	30	100	1 (8.3ms)	0.44	100	30	30	9	10	1
CD1005-B0130L	1005	35	30	100	1 (8.3ms)	0.44	100	30	30	9	10	1
CD0603-B0140L	0603	45	40	100	1 (8.3ms)	0.55	100	30	10	9	10	1
CD1005-B0140L	1005	45	40	100	1 (8.3ms)	0.55	100	30	10	9	10	1
CD0603-B0140R	0603	45	40	100	1 (8.3ms)	0.45	10	1	10	9	10	1
CD1005-B0140R	1005	45	40	100	1 (8.3ms)	0.45	10	1	10	9	10	1

Discrete Transient Voltage Suppressor (TVS) Diodes

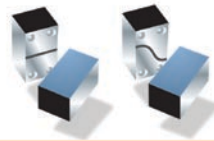

Part Number	Pkg. Size	Electrical Characterization (Ta = 25 °C)								
		V _{rrm} (V)	V _{rsm} (V)	I _{rsm} (A)	P _{pk} (W)	V _{br} min. (V)	@ I _f (mA)	C _t Typ (pF)	@ V _r (V)	@ F (MHz)
CD0402-T3.3C	0402	3.3	12.5	20	250	4	1	150	0	1
CD0402-T3.3LC	0402	3.3	12.5	20	250	4	1	70	0	1
CD0402-T05C	0402	5	14.7	17	250	6	1	100	0	1
CD0402-T05LC	0402	5	14.7	17	250	6	1	35	0	1
CD0402-T08C	0402	8	19.2	13	250	8.5	1	75	0	1
CD0402-T08LC	0402	8	19.2	13	250	8.5	1	32	0	1
CD0402-T12C	0402	12	29.7	9	250	13.3	1	50	0	1
CD0402-T12LC	0402	12	29.7	9	250	13.3	1	30	0	1
CD0402-T15C	0402	15	35.7	7	250	16.7	1	40	0	1
CD0402-T15LC	0402	15	35.7	7	250	16.7	1	25	0	1
CD0402-T24C	0402	24	55	5	250	26.7	1	30	0	1
CD0402-T24LC	0402	24	55	5	250	26.7	1	20	0	1
CD0402-T36C	0402	36	84	3	250	40	1	25	0	1
CD0402-T36LC	0402	36	84	3	250	40	1	18	0	1

Discrete Low Capacitance Transient Voltage Suppressor (TVS) Diodes

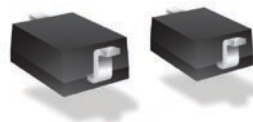

Part Number	Pkg. Size	Electrical Characterization (Ta = 25 °C)								
		V _{rrm} (V)	V _{rsm} (V)	I _{rsm} (A)	P _{pk} (W)	V _{br} min. (V)	@ I _f (mA)	C _t Typ (pF)	@ V _r (V)	@ F (MHz)
CDS0D323-T03	SOD-323	3.3	19	20	350	4	1	3	0	1
CDS0D323-T05	SOD-323	5	18.3	17	350	6	1	3	0	1
CDS0D323-T08	SOD-323	8	18.5	17	350	8.5	1	3	0	1
CDS0D323-T12	SOD-323	12	28.3	11	350	13.3	1	3	0	1
CDS0D323-T15	SOD-323	15	31.8	10	350	16.7	1	3	0	1
CDS0D323-T18	SOD-323	18	45	8	350	20	1	3	0	1
CDS0D323-T24	SOD-323	24	56	6	350	26.7	1	3	0	1
CDS0D323-T03C	SOD-323	3.3	19	20	350	4	1	3	0	1
CDS0D323-T05C	SOD-323	5	18.3	17	350	6	1	3	0	1
CDS0D323-T08C	SOD-323	8	18.5	17	350	8.5	1	3	0	1
CDS0D323-T12C	SOD-323	12	28.3	11	350	13.3	1	3	0	1
CDS0D323-T15C	SOD-323	15	31.8	10	350	16.7	1	3	0	1
CDS0D323-T18C	SOD-323	18	45	8	350	20	1	3	0	1
CDS0D323-T24C	SOD-323	24	56	6	350	26.7	1	3	0	1

Discrete 400W Transient Voltage Suppressor (TVS) Diodes

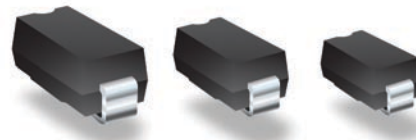

Part Number Unidirectional	Part Number Bidirectional	Pkg. Size	Electrical Characterization (Ta = 25 °C)					
			V _{rwm} (V)	V _{rsm} (V)	I _{rsm} (A)	P _{pk} (W)	V _{br min.} (V)	@ I _f (mA)
CD214A-T5.0ALF	CD214A-T5.0CALF	SMA	5	9.2	43.5	400	6.4	10
CD214A-T6.0ALF	CD214A-T6.0CALF	SMA	6	10.3	38.8	400	6.67	10
CD214A-T6.5ALF	CD214A-T6.5CALF	SMA	6.5	11.2	35.7	400	7.22	10
CD214A-T7.0ALF	CD214A-T7.0CALF	SMA	7	12	33.3	400	7.78	10
CD214A-T7.5ALF	CD214A-T7.5CALF	SMA	7.5	12.9	31	400	8.33	1
CD214A-T8.0ALF	CD214A-T8.0CALF	SMA	8	13.6	29.4	400	8.89	1
CD214A-T8.5ALF	CD214A-T8.5CALF	SMA	8.5	14.4	27.7	400	9.44	1
CD214A-T9.0ALF	CD214A-T9.0CALF	SMA	9	15.4	26	400	10	1
CD214A-T10ALF	CD214A-T10CALF	SMA	10	17	23.5	400	11.1	1
CD214A-T11ALF	CD214A-T11CALF	SMA	11	18.2	22	400	12.2	1
CD214A-T12ALF	CD214A-T12CALF	SMA	12	19.9	20.1	400	13.3	1
CD214A-T13ALF	CD214A-T13CALF	SMA	13	21.5	18.6	400	14.4	1
CD214A-T14ALF	CD214A-T14CALF	SMA	14	23.2	17.2	400	15.6	1
CD214A-T15ALF	CD214A-T15CALF	SMA	15	24.4	16.4	400	16.7	1
CD214A-T16ALF	CD214A-T16CALF	SMA	16	26	15.3	400	17.8	1
CD214A-T17ALF	CD214A-T17CALF	SMA	17	27.6	14.5	400	18.9	1
CD214A-T18ALF	CD214A-T18CALF	SMA	18	29.2	13.7	400	20	1
CD214A-T20ALF	CD214A-T20CALF	SMA	20	32.4	12.3	400	22.2	1
CD214A-T22ALF	CD214A-T22CALF	SMA	22	35.5	11.2	400	24.4	1
CD214A-T24ALF	CD214A-T24CALF	SMA	24	38.9	10.3	400	26.7	1
CD214A-T26ALF	CD214A-T26CALF	SMA	26	42.1	9.5	400	28.9	1
CD214A-T28ALF	CD214A-T28CALF	SMA	28	45.4	8.8	400	31.1	1
CD214A-T30ALF	CD214A-T30CALF	SMA	30	48.4	8.3	400	33.3	1
CD214A-T33ALF	CD214A-T33CALF	SMA	33	53.3	7.5	400	36.7	1
CD214A-T36ALF	CD214A-T36CALF	SMA	36	58.1	6.9	400	40	1
CD214A-T40ALF	CD214A-T40CALF	SMA	40	64.5	6.2	400	44.4	1
CD214A-T43ALF	CD214A-T43CALF	SMA	43	69.4	5.7	400	47.8	1
CD214A-T45ALF	CD214A-T45CALF	SMA	45	72.7	5.5	400	50	1
CD214A-T48ALF	CD214A-T48CALF	SMA	48	77.4	5.2	400	53.3	1
CD214A-T51ALF	CD214A-T51CALF	SMA	51	82.4	4.9	400	56.7	1
CD214A-T54ALF	CD214A-T54CALF	SMA	54	87.1	4.6	400	60	1
CD214A-T58ALF	CD214A-T58CALF	SMA	58	93.6	4.3	400	64.4	1
CD214A-T60ALF	CD214A-T60CALF	SMA	60	96.8	4.1	400	66.7	1
CD214A-T64ALF	CD214A-T64CALF	SMA	64	103	3.9	400	71.1	1
CD214A-T70ALF	CD214A-T70CALF	SMA	70	113	3.5	400	77.8	1
CD214A-T75ALF	CD214A-T75CALF	SMA	75	121	3.3	400	83.3	1
CD214A-T78ALF	CD214A-T78CALF	SMA	78	126	3.2	400	86.7	1
CD214A-T85ALF	CD214A-T85CALF	SMA	85	137	2.9	400	94.4	1
CD214A-T90ALF	CD214A-T90CALF	SMA	90	146	2.7	400	100	1
CD214A-T100ALF	CD214A-T100CALF	SMA	100	162	2.5	400	111	1
CD214A-T110ALF	CD214A-T110CALF	SMA	110	177	2.3	400	122	1
CD214A-T120ALF	CD214A-T120CALF	SMA	120	193	2	400	133	1
CD214A-T130ALF	CD214A-T130CALF	SMA	130	209	1.9	400	144	1
CD214A-T150ALF	CD214A-T150CALF	SMA	150	243	1.6	400	167	1
CD214A-T160ALF	CD214A-T160CALF	SMA	160	259	1.5	400	178	1
CD214A-T170ALF	CD214A-T170CALF	SMA	170	275	1.4	400	189	1

Discrete 600W Transient Voltage Suppressor (TVS) Diodes



Part Number Unidirectional	Part Number Bidirectional	Pkg. Size	Electrical Characterization (Ta = 25 °C)					
			V _{rwm} (V)	V _{rsm} (V)	I _{rsm} (A)	P _{pk} (W)	V _{br min.} (V)	@ I _f (mA)
CD214B-T5.0ALF	CD214B-T5.0CALF	SMB	5	9.2	65.2	600	6.4	10
CD214B-T6.0ALF	CD214B-T6.0CALF	SMB	6	10.3	58.3	600	6.67	10
CD214B-T6.5ALF	CD214B-T6.5CALF	SMB	6.5	11.2	53.6	600	7.22	10
CD214B-T7.0ALF	CD214B-T7.0CALF	SMB	7	12	50	600	7.78	10
CD214B-T7.5ALF	CD214B-T7.5CALF	SMB	7.5	12.9	46.5	600	8.33	1
CD214B-T8.0ALF	CD214B-T8.0CALF	SMB	8	13.6	44.1	600	8.89	1
CD214B-T8.5ALF	CD214B-T8.5CALF	SMB	8.5	14.4	41.7	600	9.44	1
CD214B-T9.0ALF	CD214B-T9.0CALF	SMB	9	15.4	39	600	10	1
CD214B-T10ALF	CD214B-T10CALF	SMB	10	17	35.3	600	11.1	1
CD214B-T11ALF	CD214B-T11CALF	SMB	11	18.2	33	600	12.2	1
CD214B-T12ALF	CD214B-T12CALF	SMB	12	19.9	30.2	600	13.3	1
CD214B-T13ALF	CD214B-T13CALF	SMB	13	21.5	27.9	600	14.4	1
CD214B-T14ALF	CD214B-T14CALF	SMB	14	23.2	25.8	600	15.6	1
CD214B-T15ALF	CD214B-T15CALF	SMB	15	24.4	24	600	16.7	1
CD214B-T16ALF	CD214B-T16CALF	SMB	16	26	23.1	600	17.8	1
CD214B-T17ALF	CD214B-T17CALF	SMB	17	27.6	21.7	600	18.9	1
CD214B-T18ALF	CD214B-T18CALF	SMB	18	29.2	20.5	600	20	1
CD214B-T20ALF	CD214B-T20CALF	SMB	20	32.4	18.5	600	22.2	1
CD214B-T22ALF	CD214B-T22CALF	SMB	22	35.5	16.9	600	24.4	1
CD214B-T24ALF	CD214B-T24CALF	SMB	24	38.9	15.4	600	26.7	1
CD214B-T26ALF	CD214B-T26CALF	SMB	26	42.1	14.2	600	28.9	1
CD214B-T28ALF	CD214B-T28CALF	SMB	28	45.4	13.2	600	31.1	1
CD214B-T30ALF	CD214B-T30CALF	SMB	30	48.4	12.4	600	33.3	1
CD214B-T33ALF	CD214B-T33CALF	SMB	33	53.3	11.3	600	36.7	1
CD214B-T36ALF	CD214B-T36CALF	SMB	36	58.1	10.3	600	40	1
CD214B-T40ALF	CD214B-T40CALF	SMB	40	64.5	9.3	600	44.4	1
CD214B-T43ALF	CD214B-T43CALF	SMB	43	69.4	8.6	600	47.8	1
CD214B-T45ALF	CD214B-T45CALF	SMB	45	72.7	8.3	600	50	1
CD214B-T48ALF	CD214B-T48CALF	SMB	48	77.4	7.7	600	53.3	1
CD214B-T51ALF	CD214B-T51CALF	SMB	51	82.4	7.3	600	56.7	1
CD214B-T54ALF	CD214B-T54CALF	SMB	54	87.1	6.9	600	60	1
CD214B-T58ALF	CD214B-T58CALF	SMB	58	93.6	6.4	600	64.4	1
CD214B-T60ALF	CD214B-T60CALF	SMB	60	96.8	6.2	600	66.7	1
CD214B-T64ALF	CD214B-T64CALF	SMB	64	103	5.8	600	71.1	1
CD214B-T70ALF	CD214B-T70CALF	SMB	70	113	5.3	600	77.8	1
CD214B-T75ALF	CD214B-T75CALF	SMB	75	121	4.9	600	83.3	1
CD214B-T78ALF	CD214B-T78CALF	SMB	78	126	4.7	600	86.7	1
CD214B-T85ALF	CD214B-T85CALF	SMB	85	137	4.4	600	94.4	1
CD214B-T90ALF	CD214B-T90CALF	SMB	90	146	4.1	600	100	1
CD214B-T100ALF	CD214B-T100CALF	SMB	100	162	3.7	600	111	1
CD214B-T110ALF	CD214B-T110CALF	SMB	110	177	3.4	600	122	1
CD214B-T120ALF	CD214B-T120CALF	SMB	120	193	3.1	600	133	1
CD214B-T130ALF	CD214B-T130CALF	SMB	130	209	2.9	600	144	1
CD214B-T150ALF	CD214B-T150CALF	SMB	150	243	2.5	600	167	1
CD214B-T160ALF	CD214B-T160CALF	SMB	160	259	2.3	600	178	1
CD214B-T170ALF	CD214B-T170CALF	SMB	170	275	2.2	600	189	1

Discrete 1500W Transient Voltage Suppressor (TVS) Diodes



Part Number Unidirectional	Part Number Bidirectional	Pkg. Size	Electrical Characterization (Ta = 25 °C)					
			V _{rw} (V)	V _{rsm} (V)	I _{rsm} (A)	P _{pk} (W)	V _{br min.} (V)	@ I _f (mA)
CD214C-T5.0ALF	CD214C-T5.0CALF	SMC	5	9.2	163	1500	6.4	10
CD214C-T6.0ALF	CD214C-T6.0CALF	SMC	6	10.3	145.6	1500	6.67	10
CD214C-T6.5ALF	CD214C-T6.5CALF	SMC	6.5	11.2	133.9	1500	7.22	10
CD214C-T7.0ALF	CD214C-T7.0CALF	SMC	7	12	125	1500	7.78	10
CD214C-T7.5ALF	CD214C-T7.5CALF	SMC	7.5	12.9	116.3	1500	8.33	1
CD214C-T8.0ALF	CD214C-T8.0CALF	SMC	8	13.6	110.3	1500	8.89	1
CD214C-T8.5ALF	CD214C-T8.5CALF	SMC	8.5	14.4	104.2	1500	9.44	1
CD214C-T9.0ALF	CD214C-T9.0CALF	SMC	9	15.4	97.4	1500	10	1
CD214C-T10ALF	CD214C-T10CALF	SMC	10	17	88.2	1500	11.1	1
CD214C-T11ALF	CD214C-T11CALF	SMC	11	18.2	82.4	1500	12.2	1
CD214C-T12ALF	CD214C-T12CALF	SMC	12	19.9	75.3	1500	13.3	1
CD214C-T13ALF	CD214C-T13CALF	SMC	13	21.5	69.7	1500	14.4	1
CD214C-T14ALF	CD214C-T14CALF	SMC	14	23.2	64.7	1500	15.6	1
CD214C-T15ALF	CD214C-T15CALF	SMC	15	24.4	61.5	1500	16.7	1
CD214C-T16ALF	CD214C-T16CALF	SMC	16	26	57.7	1500	17.8	1
CD214C-T17ALF	CD214C-T17CALF	SMC	17	27.6	53.3	1500	18.9	1
CD214C-T18ALF	CD214C-T18CALF	SMC	18	29.2	51.4	1500	20	1
CD214C-T20ALF	CD214C-T20CALF	SMC	20	32.4	46.3	1500	22.2	1
CD214C-T22ALF	CD214C-T22CALF	SMC	22	35.5	42.2	1500	24.4	1
CD214C-T24ALF	CD214C-T24CALF	SMC	24	38.9	38.6	1500	26.7	1
CD214C-T26ALF	CD214C-T26CALF	SMC	26	42.1	35.6	1500	28.9	1
CD214C-T28ALF	CD214C-T28CALF	SMC	28	45.4	33	1500	31.1	1
CD214C-T30ALF	CD214C-T30CALF	SMC	30	48.4	31	1500	33.3	1
CD214C-T33ALF	CD214C-T33CALF	SMC	33	53.3	28.1	1500	36.7	1
CD214C-T36ALF	CD214C-T36CALF	SMC	36	58.1	25.8	1500	40	1
CD214C-T40ALF	CD214C-T40CALF	SMC	40	64.5	23.3	1500	44.4	1
CD214C-T43ALF	CD214C-T43CALF	SMC	43	69.4	21.6	1500	47.8	1
CD214C-T45ALF	CD214C-T45CALF	SMC	45	72.7	20.6	1500	50	1
CD214C-T48ALF	CD214C-T48CALF	SMC	48	77.4	19.4	1500	53.3	1
CD214C-T51ALF	CD214C-T51CALF	SMC	51	82.4	18.2	1500	56.7	1
CD214C-T54ALF	CD214C-T54CALF	SMC	54	87.1	17.2	1500	60	1
CD214C-T58ALF	CD214C-T58CALF	SMC	58	93.6	16	1500	64.4	1
CD214C-T60ALF	CD214C-T60CALF	SMC	60	96.8	15.5	1500	66.7	1
CD214C-T64ALF	CD214C-T64CALF	SMC	64	103	14.6	1500	71.1	1
CD214C-T70ALF	CD214C-T70CALF	SMC	70	113	13.3	1500	77.8	1
CD214C-T75ALF	CD214C-T75CALF	SMC	75	121	12.4	1500	83.3	1
CD214C-T78ALF	CD214C-T78CALF	SMC	78	126	11.4	1500	86.7	1
CD214C-T85ALF	CD214C-T85CALF	SMC	85	137	10.4	1500	94.4	1
CD214C-T90ALF	CD214C-T90CLF	SMC	90	146	10.3	1500	100	1
CD214C-T100ALF	CD214C-T100CALF	SMC	100	162	9.3	1500	111	1
CD214C-T110ALF	CD214C-T110CALF	SMC	110	177	8.4	1500	122	1
CD214C-T120ALF	CD214C-T120CALF	SMC	120	193	7.9	1500	133	1
CD214C-T130ALF	CD214C-T130CALF	SMC	130	209	7.2	1500	144	1
CD214C-T150ALF	CD214C-T150CALF	SMC	150	243	6.2	1500	167	1
CD214C-T160ALF	CD214C-T160CALF	SMC	160	259	5.8	1500	178	1
CD214C-T170ALF	CD214C-T170CALF	SMC	170	275	5.5	1500	189	1

Discrete 3000W Transient Voltage Suppressor (TVS) Diodes

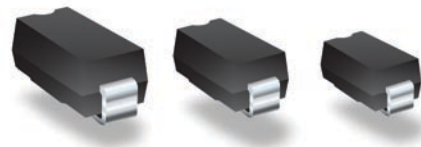

Part Number Unidirectional	Part Number Bidirectional	Pkg. Size	Electrical Characterization (Ta = 25 °C)					
			V _{rwm} (V)	V _{rsm} (V)	I _{rsm} (A)	P _{pk} (W)	V _{br min.} (V)	@ I _f (mA)
CD214L-T5.0ALF	CD214L-T5.0CALF	SMC	5	9.2	326	3000	6.4	10
CD214L-T6.0ALF	CD214L-T6.0CALF	SMC	6	10.3	291.3	3000	6.67	10
CD214L-T6.5ALF	CD214L-T6.5CALF	SMC	6.5	11.2	267.9	3000	7.22	10
CD214L-T7.0ALF	CD214L-T7.0CALF	SMC	7	12	250	3000	7.78	10
CD214L-T7.5ALF	CD214L-T7.5CALF	SMC	7.5	12.9	232.6	3000	8.33	1
CD214L-T8.0ALF	CD214L-T8.0CALF	SMC	8	13.6	220.6	3000	8.89	1
CD214L-T8.5ALF	CD214L-T8.5CALF	SMC	8.5	14.4	208.4	3000	9.44	1
CD214L-T9.0ALF	CD214L-T9.0CALF	SMC	9	15.4	194.8	3000	10	1
CD214L-T10ALF	CD214L-T10CALF	SMC	10	17	176.4	3000	11.10	1
CD214L-T11ALF	CD214L-T11CALF	SMC	11	18.2	164.8	3000	12.2	1
CD214L-T12ALF	CD214L-T12CALF	SMC	12	19.9	150.6	3000	13.3	1
CD214L-T13ALF	CD214L-T13CALF	SMC	13	21.5	139.4	3000	14.4	1
CD214L-T14ALF	CD214L-T14CALF	SMC	14	23.2	129.4	3000	15.6	1
CD214L-T15ALF	CD214L-T15CALF	SMC	15	24.4	123	3000	16.7	1
CD214L-T16ALF	CD214L-T16CALF	SMC	16	26	115.4	3000	17.8	1
CD214L-T17ALF	CD214L-T17CALF	SMC	17	27.6	106.6	3000	18.9	1
CD214L-T18ALF	CD214L-T18CALF	SMC	18	29.2	102.8	3000	20	1
CD214L-T20ALF	CD214L-T20CALF	SMC	20	32.4	92.6	3000	22.2	1
CD214L-T22ALF	CD214L-T22CALF	SMC	22	35.5	84.4	3000	24.4	1
CD214L-T24ALF	CD214L-T24CALF	SMC	24	38.9	77.2	3000	26.7	1
CD214L-T26ALF	CD214L-T26CALF	SMC	26	42.1	71.2	3000	28.9	1
CD214L-T28ALF	CD214L-T28CALF	SMC	28	45.4	66	3000	31.1	1
CD214L-T30ALF	CD214L-T30CALF	SMC	30	48.4	62	3000	33.3	1
CD214L-T33ALF	CD214L-T33CALF	SMC	33	53.3	56.2	3000	36.7	1
CD214L-T36ALF	CD214L-T36CALF	SMC	36	58.1	51.6	3000	40	1
CD214L-T40ALF	CD214L-T40CALF	SMC	40	64.5	46.4	3000	44.4	1
CD214L-T43ALF	CD214L-T43CALF	SMC	43	69.4	43.2	3000	47.8	1
CD214L-T45ALF	CD214L-T45CALF	SMC	45	72.7	41.2	3000	50	1
CD214L-T48ALF	CD214L-T48CALF	SMC	48	77.4	38.8	3000	53.3	1
CD214L-T51ALF	CD214L-T51CALF	SMC	51	82.4	36.4	3000	56.7	1
CD214L-T54ALF	CD214L-T54CALF	SMC	54	87.1	34.4	3000	60	1
CD214L-T58ALF	CD214L-T58CALF	SMC	58	93.6	32	3000	64.4	1
CD214L-T60ALF	CD214L-T60CALF	SMC	60	96.8	31	3000	66.7	1
CD214L-T64ALF	CD214L-T64CALF	SMC	64	103	29.2	3000	71.1	1
CD214L-T70ALF	CD214L-T70CALF	SMC	70	113	26.6	3000	77.8	1
CD214L-T75ALF	CD214L-T75CALF	SMC	75	121	24.8	3000	83.3	1
CD214L-T78ALF	CD214L-T78CALF	SMC	78	126	22.8	3000	86.7	1
CD214L-T85ALF	CD214L-T85CALF	SMC	85	137	20.8	3000	94.4	1
CD214L-T90ALF	CD214L-T90CALF	SMC	90	146	20.6	3000	100	1
CD214L-T100ALF	CD214L-T100CALF	SMC	100	162	18.6	3000	111	1
CD214L-T110ALF	CD214L-T110CALF	SMC	110	177	16.8	3000	122	1
CD214L-T120ALF	CD214L-T120CALF	SMC	120	193	15.60	3000	133	1
CD214L-T130ALF	CD214L-T130CALF	SMC	130	209	14.4	3000	144	1
CD214L-T150ALF	CD214L-T150CALF	SMC	150	243	12.4	3000	167	1
CD214L-T160ALF	CD214L-T160CALF	SMC	160	259	11.6	3000	178	1
CD214L-T170ALF	CD214L-T170CALF	SMC	170	275	11.00	3000	189	1

Transient Voltage Suppressor (TVS) & Steering Diode Arrays



Part Number	Pkg. Size	Absolute Max. Rating (Ta = 25 °C)			Electrical Characterization (Ta = 25 °C)							Schematic
		V _{wm} (V)	V _{br} (V)	I _o (A)	V _f max. (V)	@ I _f (mA)	I _r max. (uA)	@ V _r (mA)	C _{typ} (pF)	@ V _r (V)	@ F (MHz)	
CDSOT23-SR208	SOT23-6	20		0.7	1.2	5	1	5	3	0	1	See Page 2
CDSOT23-SR724	SOT23-6	20		0.7	1.2	5	1	5	3	0	1	
CD143A-SR2.8	SOT-143A	2.8	3.0	30	1.0	10	1	2.8	4.5	0	1	
CD143A-SR3.3	SOT-143A	3.3	3.5	30	1.0	10	1	3.3	4.5	0	1	
CD143A-SR05	SOT-143A	5.0	6.0	30	1.5	10	5	5	10	0	1	
CD143A-SR12	SOT-143A	12.0	13.3	30	1.5	10	1	12	10	0	1	
CD143A-SR70	SOT-143A	70	70	24	1.5	1000	1	70	8	0	1	
CDNBS16-SR720	NSOIC 16L	30		12	2	1000	0.02	20	3	0	1	
CDNBS08-SR720	NSOIC 8L	30		12	2	1000	0.02	20	3	0	1	
2DEA-2-Q24RLF	QSOP 24L	12		0.015	1.5	12	10	12	3	0	1	
2DTA-5-Q24RLF	QSOP 24L	7		0.050	0.75	50	5	7	3	0	1	
2DTA-10-Q24RLF	QSOP 24L	7		0.050	0.85	50	5	7	3	0	1	

Transient Voltage Suppressor (TVS) Diode Arrays

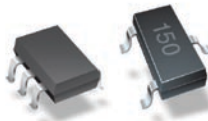

Part Number	Pkg. Size	Absolute Max. Rating (Ta = 25 °C)			Electrical Characterization (Ta = 25 °C)					Schematic
		V _{rwm} (V)	V _{rsm} (V)	I _{rsm} (A)	V _{br} min. (V)	@ I _f (mA)	C _t typ (pF)	@ V _r (V)	@ F (MHz)	
CDDFN4-T05	DFN-4	5.0	12	2	6.0	1	10.5	0	1	
CDSC706-T05C	SC70-6	5.0	12	9	6	1	60	0	1	
CDSC706-T12C	SC70-6	12	23.8	4.2	13.3	1	35	0	1	
CDSC706-T15C	SC70-6	15	33.3	3.0	16.7	1	25	0	1	
CDSC706-T24C	SC70-6	24	55.5	1.8	26.7	1	20	0	1	
CDSC706-0504F	SC70-6	5.0	25.0	5.0	6.0	1	1.9	0	1	
CDSOT23-T03	SOT23	3.3	10.9	43	4.0	1	500	0	1	
CDSOT23-T05	SOT23	5.0	13.5	42	6.0	1	350	0	1	
CDSOT23-T08	SOT23	8.0	16.9	34	8.5	1	250	0	1	
CDSOT23-T12	SOT23	12	25.9	27	13.3	1	150	0	1	
CDSOT23-T15	SOT23	15	30.0	17	16.7	1	100	0	1	
CDSOT23-T24	SOT23	24	49.0	12	26.7	1	88	0	1	
CDSOT23-T36	SOT23	36	76.8	9	40.0	1	80	0	1	
CDSOT23-T03C	SOT23	3.3	10.9	43	4.0	1	300	0	1	
CDSOT23-T05C	SOT23	5.0	13.5	42	6.0	1	210	0	1	
CDSOT23-T08C	SOT23	8.0	16.9	34	8.5	1	150	0	1	
CDSOT23-T12C	SOT23	12	25.9	27	13.3	1	90	0	1	
CDSOT23-T15C	SOT23	15	30.0	17	16.7	1	60	0	1	
CDSOT23-T24C	SOT23	24	49.0	12	26.7	1	63	0	1	
CDSOT23-T36C	SOT23	36	76.8	9	40.0	1	60	0	1	
CDSOT23-T03LC	SOT23	3.3	10.9	43	4.0	1	5	0	1	
CDSOT23-T05LC	SOT23	5.0	13.5	42	6.0	1	5	0	1	
CDSOT23-T08LC	SOT23	8.0	16.9	34	8.5	1	5	0	1	
CDSOT23-T12LC	SOT23	12	25.9	27	13.3	1	5	0	1	
CDSOT23-T15LC	SOT23	15	30.0	17	16.7	1	5	0	1	
CDSOT23-T24LC	SOT23	24	49.0	12	26.7	1	5	0	1	
CDSOT23-T36LC	SOT23	36	76.8	9	40.0	1	5	0	1	
CDSOT23-SLVU2.8	SOT23	2.8	21	30	3.0	1	2.5	0	1	
CDSOT23-SM712	SOT23	7 / 12	30	30	7.5 / 13.3	1	75	0	1	

Transient Voltage Suppressor (TVS) Diode Arrays

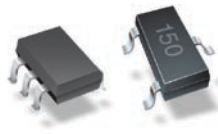

Part Number	Pkg. Size	Absolute Max. Rating (Ta = 25 °C)			Electrical Characterization (Ta = 25 °C)					Schematic	
		V _{rwm} (V)	V _{rsm} (V)	I _{rsm} (A)	V _{br min.} (V)	I _f (mA)	C _t typ (pF)	V _r (V)	F (MHz)		
CDSOT236-T05	SOT23-6	5.0	13.5	42	6.0	1	70	0	1		
CDSOT236-T12	SOT23	12	25.9	27	13.3	1	50	0	1		
CDSOT236-T15	SOT23	15	30.0	17	16.7	1	30	0	1		
CDSOT236-T24	SOT23	24	49.0	12	26.7	1	25	0	1		
CDSOT236-T05C	SOT23	5.0	13.5	42	6.0	1	70	0	1		
CDSOT236-T12C	SOT23	12	25.9	27	13.3	1	50	0	1		
CDSOT236-T15C	SOT23	15	30.0	17	16.7	1	30	0	1		
CDSOT236-T24C	SOT23	24	49.0	12	26.7	1	25	0	1		
CDSOT23-SRV05-4	SOT23	5.0	15	30	6	1	3.5	0	1	See Page 3	
CDNBS08-T03	8L NSOIC	3.0	10.9	43	3.3	1	800	0	1		
CDNBS08-T05	8L NSOIC	5.0	13.5	42	6.0	1	550	0	1		
CDNBS08-T08	8L NSOIC	8.0	16.9	34	8.5	1	500	0	1		
CDNBS08-T12	8L NSOIC	12	25.9	27	13.3	1	185	0	1		
CDNBS08-T15	8L NSOIC	15	30.0	17	16.7	1	140	0	1		
CDNBS08-T24	8L NSOIC	24	49.0	12	26.7	1	88	0	1		
CDNBS08-T36	8L NSOIC	36	76.8	9	40.0	1	80	0	1		
CDNBS08-T03C	8L NSOIC	3.0	10.9	43	3.3	1	450	0	1		
CDNBS08-T05C	8L NSOIC	5.0	13.5	42	6.0	1	308	0	1		
CDNBS08-T08C	8L NSOIC	8.0	16.9	34	8.5	1	300	0	1		
CDNBS08-T12C	8L NSOIC	12	25.9	27	13.3	1	105	0	1		
CDNBS08-T15C	8L NSOIC	15	30.0	17	16.7	1	80	0	1		
CDNBS08-T24C	8L NSOIC	24	49.0	12	26.7	1	50	0	1		
CDNBS08-T36C	8L NSOIC	36	76.8	9	40.0	1	45	0	1		
CDNBS08-PLC03-3.3	8L NSOIC	3.0	11	50	3.3	1	8	0	1		
CDNBS08-PLC03-6	8L NSOIC	6.0	20	100	6.8	1	8	0	1		
CDNBS08-SLVU2.8-4	8L NSOIC	2.8	21	30	3.0	1	6	0	1		
CDNBS08-SLVU2.8-8	8L NSOIC	2.8	17	30	3.0	1	6	0	1		
CDNBS08-SRDA3.3-4	8L NSOIC	3.0	10.9	43	4.0	1	15	0	1		
CDNBS08-SRDA05-4	8L NSOIC	5.0	13.5	42	6.0	1	15	0	1		
CDNBS08-SRDA12-4	8L NSOIC	12	25.9	27	13.3	1	15	0	1		
CDNBS08-SRDA15-4	8L NSOIC	15	30.0	17	16.7	1	15	0	1		
CDNBS08-SRDA3.3-6	8L NSOIC	3.0	10.9	43	4.0	1	15	0	1		
CDNBS08-SRDA05-6	8L NSOIC	5.0	13.5	42	6.0	1	15	0	1		
CDNBS08-USB3B	8L NSOIC	3.3	12.9	37	4.0	1	15	0	1		
CDNBS08-USB6B	8L NSOIC	5.25	13.2	35	6.0	1	15	0	1		
CDNBS16-T03	16L NSOIC	3.0	23	43	4.5	1	15	0	1		
CDNBS16-T05	16L NSOIC	5.0	24	42	6.0	1	15	0	1		
CDNBS16-T08	16L NSOIC	8.0	26	30	8.5	1	15	0	1		
CDNBS16-T12	16L NSOIC	12	33	21	13.3	1	15	0	1		
CDNBS16-T15	16L NSOIC	15	39	15	16.7	1	15	0	1		
CDNBS16-T24	16L NSOIC	24	57	10	26.7	1	15	0	1		
CDNBS16-T36	16L NSOIC	36	72	7	40.0	1	15	0	1		
CDNBS16-T03C	16L NSOIC	3.0	23	43	4.5	1	15	0	1		
CDNBS16-T05C	16L NSOIC	5.0	24	42	6.0	1	15	0	1		
CDNBS16-T08C	16L NSOIC	8.0	26	30	8.5	1	15	0	1		
CDNBS16-T12C	16L NSOIC	12	33	21	13.3	1	15	0	1		
CDNBS16-T15C	16L NSOIC	15	39	15	16.7	1	15	0	1		
CDNBS16-T24C	16L NSOIC	24	57	10	26.7	1	15	0	1		
CDNBS16-T36C	16L NSOIC	36	72	7	40.0	1	15	0	1		
CDNBS16-PLC05-6	16L NSOIC	5.0	9.6	5	6.0	1	15	0	1	See Page 3	
CDWBS16-PLC01-6	16L WSOIC	6	16	200	8	1	50	0	1		

Discrete ChipGuard® ESD Suppressors

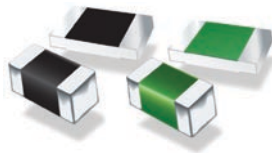

Part Number	Pkg. Size	Temp. Range		Electrical Characterization (Ta = 25 °C)						
		min. (°C)	max. (°C)	V _{DC} Typ 50 uA (V)	I _L max. @ VDC (nA)	C Typ 1 V 1 MHz (pF)	C max. 1V 1MHz (pF)	T _d max. (ns)	V _C max. 1A 8/20 uS (V)	V _t Typ (V)
CG0402MLA-5.5MG	0402	-55	125	5.5		300		1	19	150
CG0402MLA-14KG	0402	-55	125	14		100		1	38	150
CG0402MLA-18KG	0402	-55	125	18		95		1	45	150
CG0603MLA-5.5ME	0603	-55	125	5.5		300		1	19	150
CG0603MLA-14KE	0603	-55	125	14		160		1	35	150
CG0603MLA-18KE	0603	-55	125	18		140		1	40	150
CG0603MLA-26KE	0603	-55	125	26		120		1	58	150
CG0402MLC-3.3LG	0402	-40	85	3.3	5	0.2	0.5	1	25	250
CG0402MLC-3.3LGA	0402	-40	125	3.3	5	0.2	0.5	1	25	250
CG0402MLC-05LG	0402	-40	85	5	5	0.2	0.5	1	25	250
CG0402MLC-05LGA	0402	-40	125	5	5	0.2	0.5	1	25	250
CG0402MLC-12LG	0402	-40	85	12	5	0.2	0.5	1	25	250
CG0402MLC-12LGA	0402	-40	125	12	5	0.2	0.5	1	25	250
CG0603MLC-3.3LE	0603	-40	85	3.3	5	0.2	0.5	1	25	250
CG0603MLC-3.3LEA	0603	-40	125	3.3	5	0.2	0.5	1	25	250
CG0603MLC-05E	0603	-40	85	5	10	0.2	0.5	1	30	150
CG0603MLC-05LE	0603	-40	85	5	5	0.2	0.5	1	25	250
CG0603MLC-05LEA	0603	-40	125	5	5	0.2	0.5	1	25	250
CG0603MLC-12E	0603	-40	85	12	10	0.2	0.5	1	30	250
CG0603MLC-12LE	0603	-40	85	12	5	0.2	0.5	1	25	250
CG0603MLC-12LEA	0603	-40	125	12	5	0.2	0.5	1	25	250
CG0402MLD-12G	0402	-30	85	8	1000	3	5	1	140	150
CG0603MLD-12E	0603	-30	85	8	1000	3	5	1	140	150
CG0402MLE-18G	0402	-55	125	12	10000	7	9	1	50	150
CG0603MLE-18E	0603	-55	125	12	10000	40	50	1	60	150
CG0402MLU-3.3G	0402	-40	125	3.3	5	0.02	0.05	1	25	250
CG0402MLU-05G	0402	-40	125	5	5	0.02	0.05	1	25	250
CG0402MLU-12G	0402	-40	125	12	5	0.02	0.05	1	25	250
CG0402MLU-24G	0402	-40	125	24	5	0.02	0.05	1	25	250
CG0603MLU-3.3E	0603	-40	125	3.3	5	0.02	0.05	1	25	250
CG0603MLU-05E	0603	-40	125	5	5	0.02	0.05	1	25	250
CG0603MLU-12E	0603	-40	125	12	5	0.02	0.05	1	25	250
CG0603MLU-24E	0603	-40	125	24	5	0.02	0.05	1	25	250

ChipGuard® ESD Suppressor Arrays

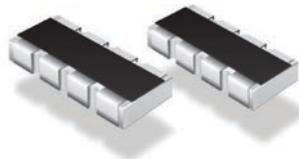

Part Number	Pkg. Size	Temp. Range		Electrical Characterization (Ta = 25 °C)						
		min. (°C)	max. (°C)	V _{DC} Typ 10 uA (V)	I _L max. @ VDC (nA)	C Typ 1 V 1 kHz (pF)	C Typ 1 V 1 MHz (pF)	T _d max. (ns)	V _C max. 1A 8/20 uS (V)	V _t Typ (V)
CG0805MLA-5.5ME	0805	-40	85	5.5		36	33	1	28	150
CG0805MLA-18KE	0805	-40	85	14		17	15	1	58	150
CG1206MLC-12E	1206	-40	85	12	10	0.3		1		150

Bourns® ChipGuard® ESD Suppressors

Competitive Cross Reference

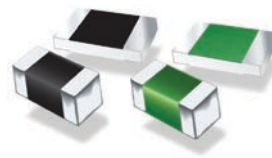

Bourns Part Number	Package	Littelfuse	Raychem	Panasonic	TDK
CG0402MLA-5.5MG	0402	V5.5MLA0402			AVR-M1005C080MTACB
CG0402MLA-14KG	0402	V14MLA0402			
CG0402MLA-18KG	0402	V18MLA0402			
CG0603MLA-5.5ME	0603	V5.5MLA0603		EZJZ1V120KA	AVR-M1608C080MTAAB
CG0603MLA-14KE	0603	V14MLA0603			
CG0603MLA-18KE	0603	V18MLA0603		EZJZ1V270GA	AVR-M1608C220KT6AB
CG0603MLA-26KE	0603	V26MLA0603		EZJZ1V330GA	AVR-M1608C270KT2AB
CG0603MLC-05E	0603	PGB0010603		EZJZ1V500AA	
CG0603MLC-12E	0603		PESD0603-140		
CG0402MLD-12G	0402				
CG0603MLD-12E	0603				
CG0402MLE-18G	0402	V18MLE0402			
CG0603MLE-18E	0603	V18MLE0603			
CG0402MLC-05LG	0402		PESD0402-060		
CG0402MLC-05G	0402		PESD0402-060		
CG0603MLC-12E	0603		PESD0603-140		
CG0603MLC-12LE	0603		PESD0603-140		
CG0603MLU-24E	0603	PGB1010603NR		EZAEG3A50AV	
CG0402MLU-24G	0402			EZAEG2A50AX	

Bourns Part Number	Package	AVX	Cooper Bussman	Epcos
CG0402MLA-5.5MG	0402	VC040205X150		
CG0402MLA-14KG	0402	VC040214X300		
CG0402MLA-18KG	0402	VC040218X400		
CG0603MLA-5.5ME	0603	VC060305A150		CT0603M4G OR CN0603M4G
CG0603MLA-14KE	0603	VC060314A300		CT0603K11G OR CN0603K11G
CG0603MLA-18KE	0603	VC060318A400		CT0603K14G OR CN0603K14G
CG0603MLA-26KE	0603	VC060326A580		CT0603K17G OR CN0603K17G
CG0603MLC-05E	0603			
CG0603MLC-12E	0603			
CG0402MLD-12G	0402			CT0402V150RFG
CG0603MLD-12E	0603			CDS3C16GTH
CG0402MLE-18G	0402			
CG0603MLE-18E	0603			
CG0402MLC-05LG	0402			
CG0402MLC-05G	0402			
CG0603MLC-12E	0603			
CG0603MLC-12LE	0603			
CG0603MLU-24E	0603		0603ESDA-TR1	
CG0402MLU-24G	0402			

Bourns® TVS Diode Arrays

Competitive Cross Reference

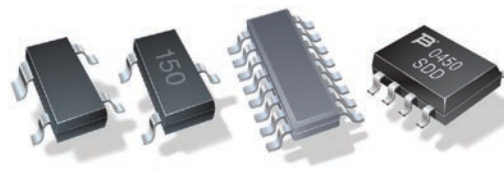

Bourns	Semtech	Littelfuse	STM	OnSemi	MicroSemi
CDSOT23-SLVU2.8	SLVU2.8.TCT				SLVU2.8K
CDSOT23-SM712	SM712.TCT				
CDSOT23-T05C	SMS.TCT	SP0502BAHT	ESDA6V1L		
CDSOT23-T12C	SM12.TCT		ESDA14V2L		
CDSOT23-T15C	SM15.TCT				
CDSOT23-T24C	SM24.TCT		ESDA25L		
CDSOT23-T36C	SM36.TCT				
CDSOT23-T05LC	SL05.TCT		ESDA6V1-4BC6	SL05T1G	
CDSOT23-T12LC	SL12.TCT				
CDSOT23-T15LC	SL15.TCT			SL15T1G	
CDSOT23-T24LC	SL24.TCT			SL24T1G	
CDSOT236-T05	SMS05.TCT	SP0504BAHT			
CDSOT236-T12	SMS12.TCT				
CDSOT236-T15	SMS15.TCT				
CDSOT236-T24	SMS24.TCT				
CDSOT236-T05C	SMS05C.TCT	SP0505BAHT	ESDA6V1-5SC6		
CDSOT236-T12C	SMS12C.TCT				
CDSOT236-T15C	SMS15C.TCT		ESDA17-5SC6		
CDSOT236-T24C	SMS24C.TCT		ESDA19-5SC6		
CDSC706-T05C	SMF05C.TCT	SP0505BAJT		SMF05C.TCT	
CDSC706-T12C	SMG12C.TCT				
CDSC706-T15C	SMF15C.TCT				
CDSC706-T24C	SMF24C.TCT				
CDSOT23-SRV05-4	SRV05-4.TCT		USBLC6-4SC6	NUP4201MR6T1G	
CDSC706-0504F	RClamp0504F			NUP4202W1T2G	
CDSOT23-SR208			DALC208SC6		
CDSOT23-SR724				NUP4301MR6T1G	
CD143A-SR2.8	SR2.8.TCT				
CD143A-SR3.3	SR3.3.TCT				
CD143A-SR05	SR05.TCT				
CD143A-SR12	SR12.TCT				
CD143A-SR70	SR70.TCT				
CDNBS08-PLC03-3.3	LC03-3.3.TCT				
CDNBS08-PLC03-6	LC03-6.TCT			LC03-6R2	
CDNBS08-SLVU2.8-4	SLVU2.8-4.TCT				SLVU2.8K-4
CDNBS08-SLVU2.8-8	SLVU2.8-8.TCT				
CDNBS08-SRDA3.3-4	SRDA3.3-4.TCT				
CDNBS08-SRDA05-4	SRDA05-4.TCT			SRDA05-4R2	
CDSNBS08-SRDA12-4	SRDA12-4.TCT				
CDNBS08-SRDA15-4	SRDA15-4.TCT				
CDNBS08-SRDA3.3-6	SRDA3.3-6.TCT				
CDNBS08-SRDA05-6	SRDA05-6.TCT			NUP4201D	
CDNBS08-USB3B			USB3B		
CDNBS08-USB6B			USB6B		
CDNBS08-T03					SMDB03E3
CDNBS08-T05	SMDA05.TCT				SMDB05E3
CDNBS08-T08					SMDB08E3
CDNBS08-T12	SMDA12.TCT				SMDB12E3
CDNBS08-T15	SMDA15.TCT				SMDB15E3
CDNBS08-T24	SMDA24.TCT				SMDB24E3
CDNBS08-T03C					SMDB03CE3
CDNBS08-T05C	SMDA05C.TCT				SMDB05CE3
CDNBS08-T08C					SMDB08CE3
CDNBS08-T12C	SMDA12C.TCT				SMDB12CE3
CDNBS08-T15C	SMDA15C.TCT				SMDB15CE3
CDNBS08-T24C	SMDA24C.TCT				SMDB24CE3
CDNBS16-T12	LCDA12-8.TCT				
CDNBS16-T15	LCDA15-8.TCT				



Worldwide Sales Offices

Country	Phone	Fax
Benelux:	+41 (0)41 768 5555	+41 (0)41 768 5510
Brazil:	+55 11 5505 0601	+55 11 5505 4370
China:	+86 21 64821250	+86 21 64821249
France:	+33 (0)2 5473 5151	+33 (0)2 5473 5156
Germany:	+49 (0)69 800 78212	+49 (0)69 800 78299
Ireland/UK:	+44 (0)1276 691087	+44 (0)1276 691088
Italy:	+41 (0)41 768 5555	+41 (0)41 768 5510
Japan:	+81 49 269 3204	+81 49 269 3297
Malaysia (KL Office):	+60 3 71183138	+60 3 71183139
Malaysia (Penang Office):	+60 4 6581771	+60 4 6582771
Singapore:	+65 6348 7227	+65 6348 1272
Switzerland:	+41 (0)41 768 5555	+41 (0)41 768 5510
Taiwan:	+886 2 25624117	+886 2 25624116
UK/Ireland:	+44 (0)1276 691087	+44 (0)1276 691088
USA:	+1-951-781-5500	+1-951-781-5006

Non-Listed European Countries:

+41 (0)41 768 5555 +41 (0)41 768 5510

Technical Assistance

Region	Phone	Fax
Asia-Pacific:	+886 2 25624117	+886 2 25624116
Europe:	+41 (0)41 768 5555	+41 (0)41 768 5510
North America:	+1-951-781-5500	+1-951-781-5700

www.bourns.com

Bourns® products are available through an extensive global network of representatives and distributors. To obtain technical applications assistance, a quotation, or to place an order, contact a Bourns representative in your area.

Specifications subject to change without notice. Actual performance in specific customer applications may differ due to the influence of other variables. Customers should verify actual device performance in these specific applications.



"Bourns", "Multifuse" and "ChipGuard" are registered trademarks of Bourns, Inc. in the U.S. and other countries.

COPYRIGHT © 2008, BOURNS, INC. • LITHO IN U.S.A. • XX 03/08 • XX/ESD0803